



# T-1<sup>3/4</sup> (5 mm ) Dual Color Indicator LED Lamp

LTL-30EDJ Yellow and Green

LTL-30EFJ Bright Red and Green

LTL-30EHJ Red Orange and Green

## Features

- T-1<sup>3/4</sup> type package.
- Long life solid state reliability.
- Low power consumption.
- I.C. compatible.

## Description

The LTL-30EXJ bipolar indicator lamp is a white diffused, with dual chips .

The viewing angle is wide.

The dual chips are operating Dependently of each other.

The Green LED is utilizing Gap on Gap.

The Yellow LED is utilizing GaAsp on Gap.

The Red Orange LED is utilizing GaAsp on Gap.

The Bright Red LED is utilizing GaAsp on Gap.

## Package Dimensions

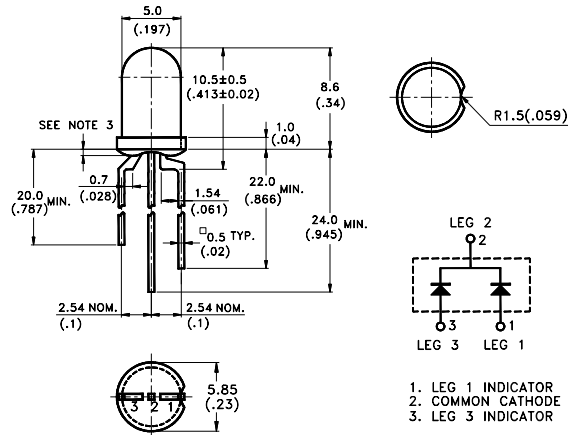

Part No. LTL-	Leg1	Leg2	Leg3
30EDJ	Yellow Anode	C. C	Green Anode
30EFJ	Bright Red Anode	C. C	Green Anode
30EHJ	Red Orange Anode	C. C	Green Anode

## Devices

Part No. LTL-	Lens	Source Color
30EDJ	White Diffused	Green
		Yellow
30EFJ	White Diffused	Green
		Bright Red
30EHJ	White Diffused	Green
		Red Orange

### Notes:

1. All dimensions are in millimeters (inches).
2. Tolerance is ± 0.25mm (.010") unless otherwise noted.
3. Protruded resin under flange is 1.0mm (.04") max.
4. Lead spacing is measured where the leads emerge from the package.
5. Specifications are subject to change without notice.

### Absolute Maximum Ratings at Ta=25°C

Parameter	Green	Yellow	Red Orange	Bright Red	Unit
Power Dissipation	100	60	100	40	mW
Peak Forward Current (1/10 Duty Cycle, 0.1ms Pulse Width)	120	80	120	60	mA
Continuous Forward Current	30	20	30	15	mA
Derating Linear From 50°C	0.4	0.25	0.4	0.2	mA/°C
Reverse Voltage	5	5	5	5	V
Operating Temperature Range	-55°C to +100°C				
Storage Temperature Range	-55°C to +100°C				
Lead Soldering Temperature [1.6mm (.063 in.) from body]	260°C for 5 Seconds				

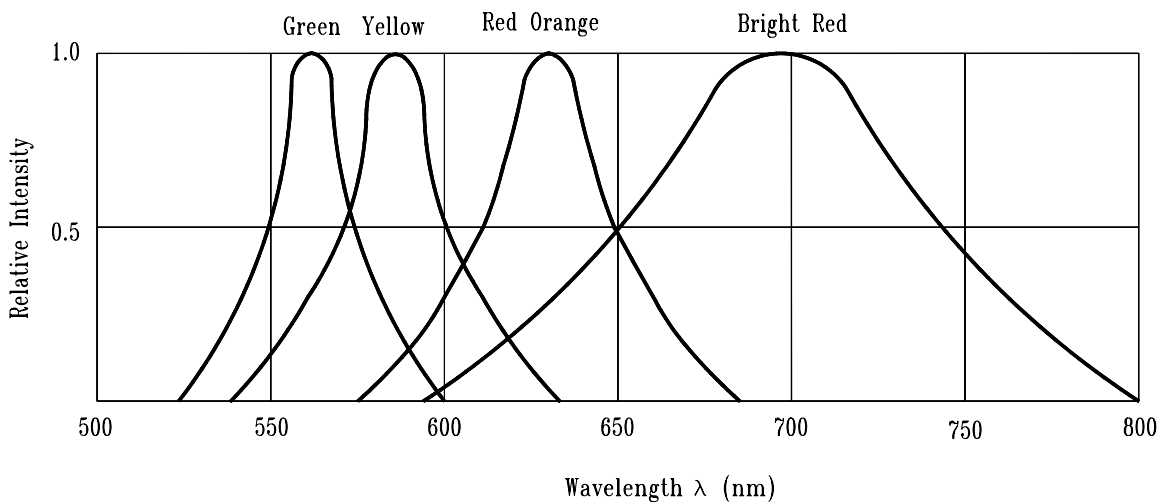

Fig.1 Relative Intensity vs. Wavelength

## Electrical / Optical Characteristics and Curves at Ta=25°C

Parameter	Symbol	Part No. LTL-	Color	Min.	Typ.	Max.	Unit.	Test Condition.
Luminous Intensity	Iv	30EDJ	Green	8.7	29		mcd	If=20 mA Note 1,4
			Yellow	8.7	29			
		30EFJ	Bright Red	1.7	5.6			If=10 mA Note 1,4
			Green	5.6	19			
		30EHJ	Red Orange	12.6	40			If=20 mA Note 1,4
			Green	8.7	29			
Viewing Angle	$2\theta_{1/2}$	30ExJ			30		deg	Note 2 (Fig.7)
Peak Emission Wavelength	$\lambda P$	30EDJ	Green		565		nm	Measurement @Peak (Fig.1)
			Yellow		585			
		30EFJ	Bright Red		697			
			Green		565			
		30EHJ	Red Orange		630			
			Green		565			
Dominant Wavelength	$\lambda d$	30EDJ	Green		569		nm	Note 3
			Yellow		588			
		30EFJ	Bright Red		697			
			Green		569			
		30EHJ	Red Orange		621			
			Green		569			
Spectral Line Half Width	$\Delta\lambda$	30EDJ	Green		30		nm	
			Yellow		35			
		30EFJ	Bright Red		90			
			Green		30			
		30EHJ	Red Orange		40			
			Green		30			
Forward Voltage	VF	30EDJ	Green		2.1	2.6	V	If=20mA
			Yellow		2.1	2.6		
		30EFJ	Bright Red		2.1	2.6		
			Green		2.1	2.6		
		30EHJ	Red Orange		2.0	2.6		
			Green		2.1	2.6		
Reverse Current	IR	30ExJ				100	$\mu A$	VR=5V
Capacitance	C	30EDJ	Green		35		pF	VF=0, f=1MHz
			Yellow		15			
		30EFJ	Bright Red		55			
			Green		35			
		30EHJ	Red Orange		20			
			Green		35			

Notes:1.Luminous intensity is measured with a light sensor and filter combination that approximates the CIE eye-response curve.

2.  $\theta_{1/2}$  is the off-axis angle at which the luminous intensity is half the axial luminous intensity.

3.The dominant wavelength,  $\lambda d$  is derived from the CIE chromaticity diagram and represents the single wavelength which defines the color of the device.

4.Iv needs  $\pm 15\%$  additionaly for guaranteed limits.

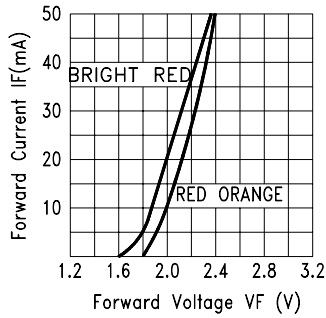

Fig.2 FORWARD CURRENT VS. FORWARD VOLTAGE

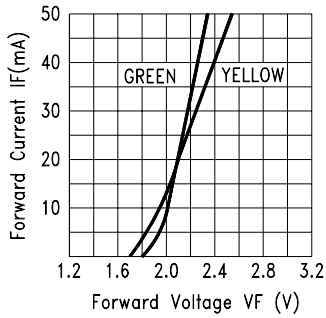

Fig.3 FORWARD CURRENT VS. FORWARD VOLTAGE

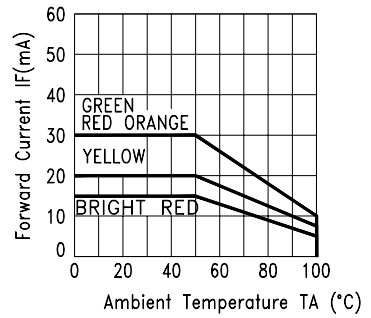

Fig.4 FORWARD CURRENT DERATING CURVE

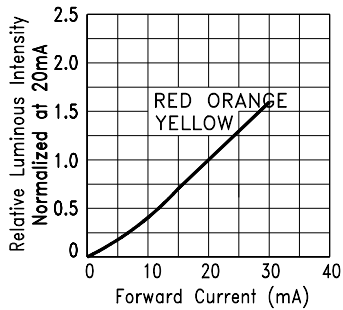

Fig.5 RELATIVE LUMINOUS INTENSITY VS. FORWARD CURRENT

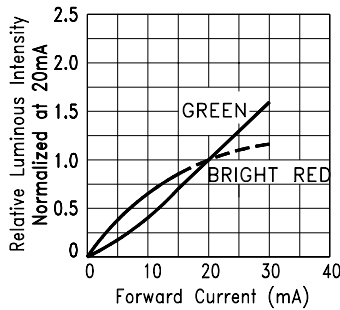

Fig.6 RELATIVE LUMINOUS INTENSITY VS. FORWARD CURRENT

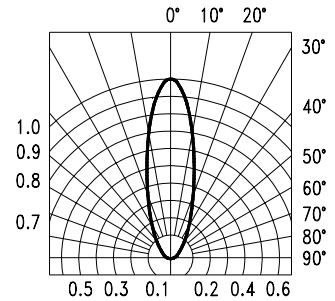

Fig.7 SPATIAL DISTRIBUTION

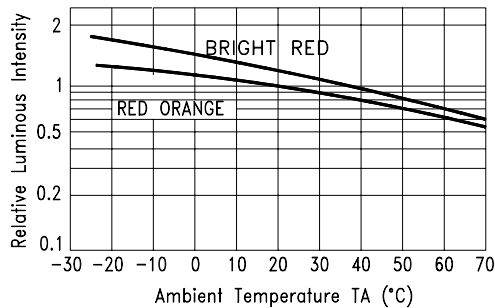

Fig.8 LUMINOUS INTENSITY VS. AMBIENT TEMPERATURE

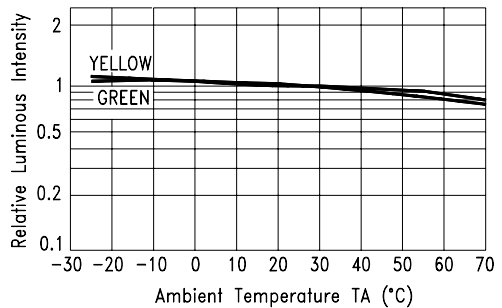

Fig.9 LUMINOUS INTENSITY VS. AMBIENT TEMPERATURE